

J. D. Hall,

Grinding Pearl Button Blanks.

No. 99,183,

Patented Jan. 25. 1870.

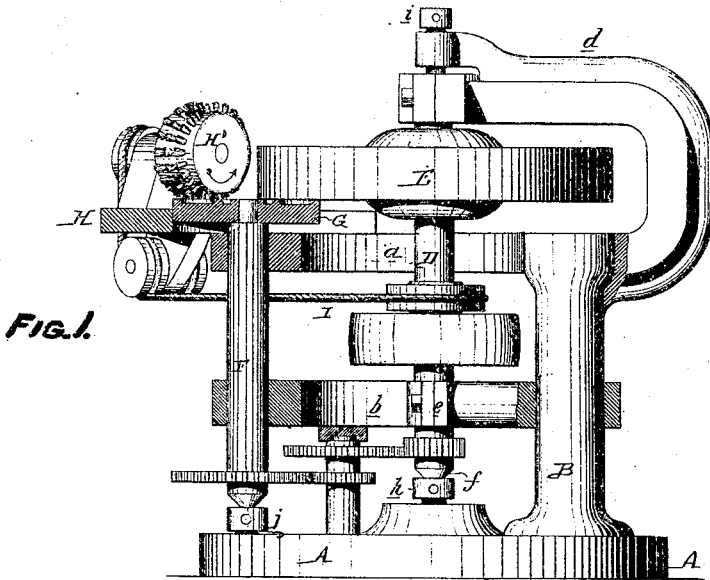

FIG. 1.

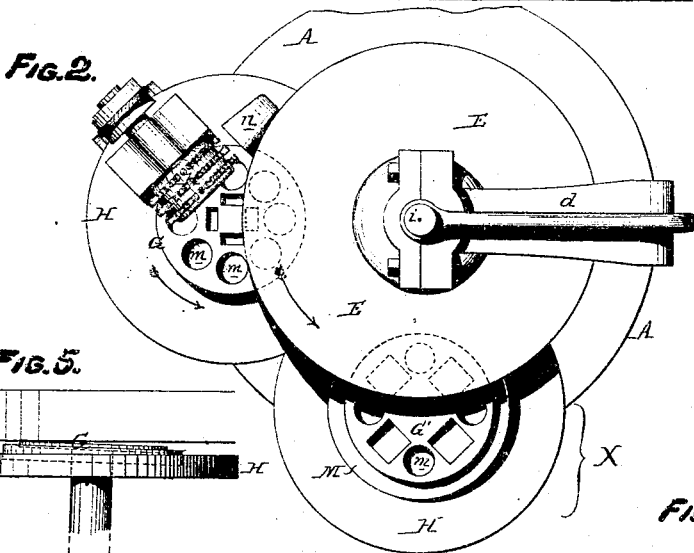

FIG. 2.

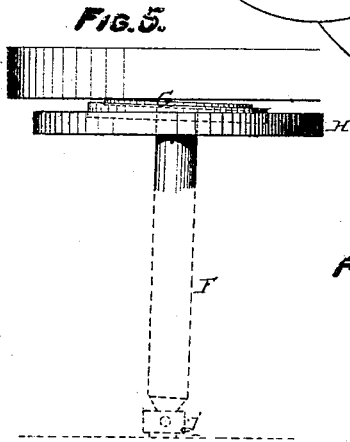

FIG. 5.

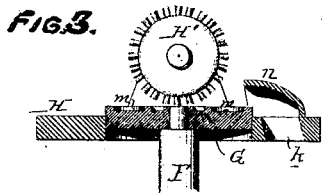

FIG. 3.

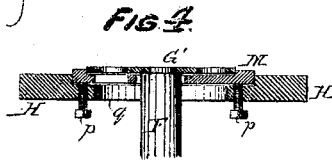

FIG. 4.

WITNESSES

Wm. A. Steel
Jno. B. Harding

John D. Hall
by his Alter.
Sturzen and son

United States Patent Office.

JOHN D. HALL, OF PHILADELPHIA, PENNSYLVANIA, ASSIGNOR TO JAMES A. LARGAY, OF SAME PLACE.

Letters Patent No. 99,183, dated January 25, 1870.

IMPROVEMENT IN MACHINE FOR GRINDING PEARL BUTTON-BLANKS.

The Schedule referred to in these Letters Patent and making part of the same.

I, JOHN D. HALL, of Philadelphia, county of Philadelphia, State of Pennsylvania, have invented a Machine for Grinding Pearl Button-Blanks and other Objects, of which the following is a specification.

Nature and Object of the Invention.

My invention consists of certain mechanism, fully described hereafter, for rapidly grinding and polishing small disks of mother-of-pearl, for pearl buttons, and for grinding and polishing other objects.

Description of the Accompanying Drawing.

Figure 1 is a side view, partly in section, of my machine for grinding pearl button-blanks and other objects;

Figure 2, a plan view;

Figure 3, a detached sectional view of part of the machine;

Figure 4 represents a modification of my invention; and

Figure 5, another modification.

General Description.

A is the base of the machine, from which projects the column B, carrying the two horizontal frames, *a* and *b*, and the bent stationary arm *d*.

D is the vertical driving-shaft, turning in a suitable bearing, *e*, on the frame *b*, and having a conical termination, *f*, adapted to a recess in a set-screw, *h*, which forms a step adjustable in the foundation-plate A.

The upper bearing of the driving-shaft is at the outer end of the stationary arm *d*, which is provided with a set-screw, *i*, the point of which bears against the upper end of the shaft.

As this shaft has to carry a heavy grindstone or wheel, E, of vulcanite emery, and has to revolve very rapidly, it is necessary to provide it with substantial bearings, and such adjusting-devices that it may revolve truly and steadily after the vertical adjustment which the shaft occasionally requires.

A vertical shaft, F, is arranged to turn in the frames *a* and *b*, and is supported by an adjustable step, *j*, in the base-plate, this shaft being driven slowly from the main driving-shaft, by a system of gearing which will be readily understood by reference to fig. 1 of the drawing, which gearing may be modified without departing from the main feature of the invention.

To the top of the shaft F is secured a circular plate, G, the periphery of which is arranged to revolve in close proximity to, but free from contact with the edge of an opening in a platform, H, projecting from the frame *a*.

In the face of the disk is a number of circular recesses, *m*, for receiving the blanks to be ground or polished by the under face of the wheel E, and in contact with the face of plate G, a circular brush, H', is caused to revolve rapidly, in the present instance by a

band, I, from the driving-shaft, in a manner which will be readily understood by reference to the drawing.

In the platform H is an opening, *k*, which is partly covered by a hood, *n*, and the purpose of which will be described hereafter.

While the grinding-wheel E is caused to revolve rapidly in the direction of its arrow, fig. 2, the disk-wheel G will turn slowly in the direction of its arrow, the brush H', at the same time, revolving rapidly over the face of the disk, in the direction indicated.

An attendant, stationed near the machine, has at hand a supply of small disks, of mother-of-pearl or other material, to be ground, and deposits one in each of the empty recesses *m* of the plate G, as the latter turns slowly, the plate carrying the disk beneath the grinding or polishing-wheel, which reduces it to an uniformly level and smooth surface.

Thus disk after disk is carried round with the plate G, and submitted to the action of the wheel E, and as the ground and polished disks, after passing with the plate from beneath the wheel, come within the range of the revolving-brush H', they are thrown by the latter toward the hood *n*, and are directed by this hood through the opening *k*, into any suitable receptacle.

It is important that the edges of the small disks should not strike the grinding-wheel abruptly; otherwise they might be displaced. In order to avoid this, I place the shaft F, which carries the plate G, in a slightly-inclined position, so that the plate will revolve, not horizontally, but in a slightly-oblique plane, as seen in fig. 5, and the inclination of the plate is such that the small disks carried by it will, on first passing beneath the grinding-wheel, be barely in contact therewith, but will gradually be brought to bear against its under side, and before leaving the wheel will receive its full effect.

A modification of my invention is illustrated at X, in fig. 2, and by the sectional view, fig. 4.

In this case, a stationary plate is so fitted in a recess in the platform H as to be rendered adjustable therein by means of set-screws *p p*; and in a recess in this plate revolves the plate G', for carrying the disks or other objects beneath the grinding-wheel.

The plate G' is perforated, for receiving the objects to be ground, and these objects rest on the plate *m* below, and after being subjected to the action of the grinding-wheel, they pass through an opening, *q*, in the lower plate, into any suitable receptacle.

It will be evident that a number of plates, G, may be employed in connection with one grinding or polishing-wheel.

It will be understood that in many cases the objects to be ground have to be square or oblong, or of other shapes, and that the recesses in the carrying-plate G, or the holes in the plate G', must have a corresponding shape, but a trifle larger.

I have heretofore alluded to mother-of-pearl as the material for grinding which the machine has been designed, but while its use for the manufacture of pearl buttons or pearl ornaments for inlaid work may be most general, there are objects of other material, ornamental stones, for instance, in grinding which the machine may be used to advantage.

I do not desire to claim, broadly, a revolving grinding-disk, partly overlapping a revolving disk, containing the articles to be ground, as this device may be seen in the patent granted to H. W. Harper.

Claims.

1. A revolving grinding or polishing-wheel, E, in combination with the recessed revolving plate G and with a revolving brush or its equivalent, whereby the contents of the recesses in the said plate may be removed therefrom, as set forth.

2. So arranging the said plate G, that it shall re-

volve in a plane obliquely, in respect to that in which the under side of the grinding-disk revolves, as set forth.

3. The combination of the revolving plate G, the revolving brush, and the hood n, above the opening k, in the platform H.

4. The combination, with the revolving grinding-wheel, of a perforated plate, G', revolving above a plate, M, as described.

5. The plate M, rendered adjustable in respect to the plate G', as set forth.

In testimony whereof, I have signed my name to this specification, in the presence of two subscribing witnesses.

JOHN D. HALL.

Witnesses:

JOHN WHITE,
HARRY SMITH.